

Ablaze Back-Lit Mirrors

Premium Back-Lit Mirrors

Installation Guide

Please read these instructions carefully and in full before installation.
Installation should be carried out by a qualified electrician.

Contents

Installation	3
Technical Specifications	5
Safety & Care Information	6
Warranty Information	7
Contact Us	8

Installation

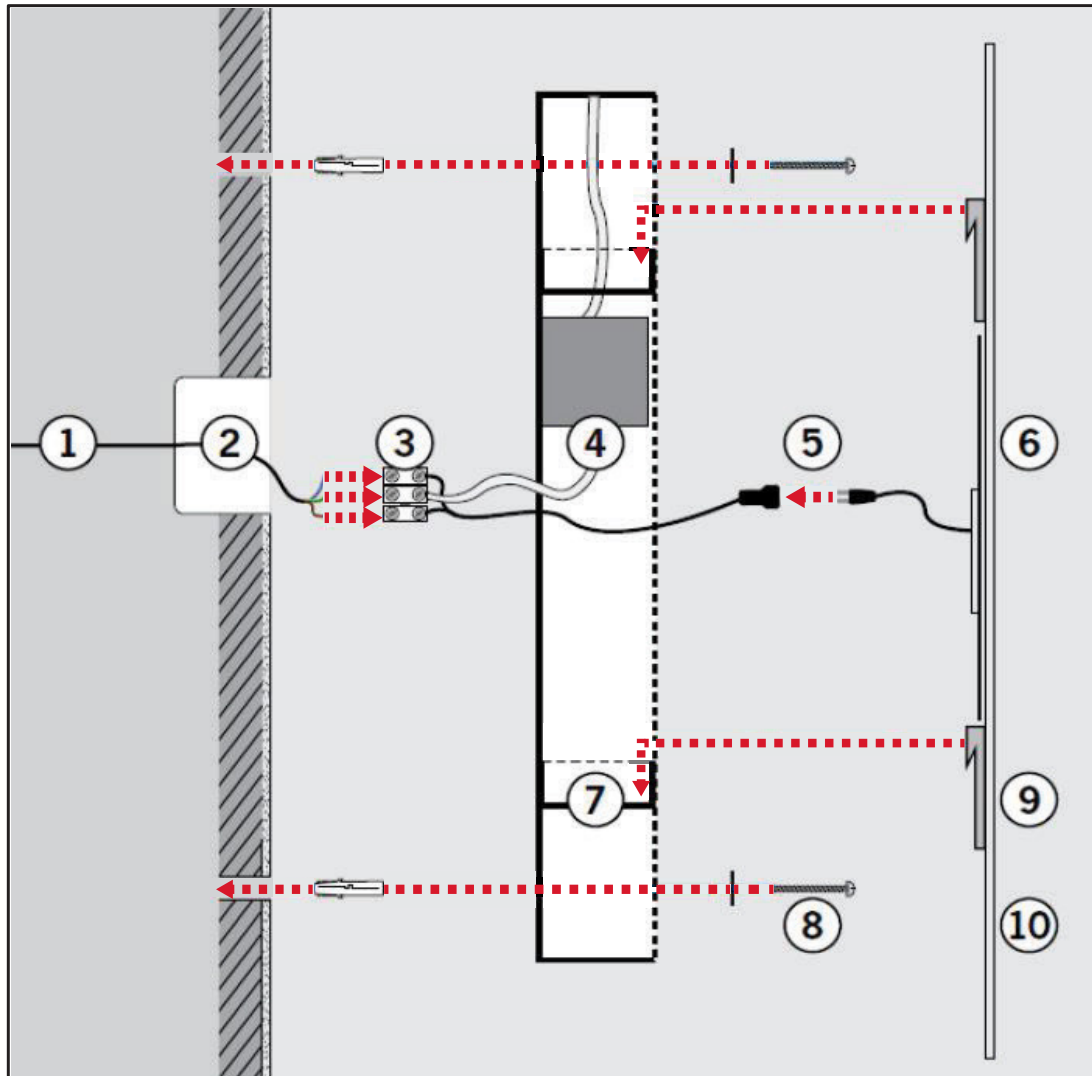

Key

- | | |
|------------------------|----------------------|
| 1. Wall & mains supply | 6. Heating element |
| 2. Junction box | 7. Backbox |
| 3. Connection block | 8. Screw & wall plug |
| 4. Transformer | 9. Metal hanger |
| 5. Demister connection | 10. Mirror |

The Ablaze Premium Back-Lit Mirror models in this guide are designed to be concealed wired (hardwired) through the back of the mirror and wired into a separate switch, timer or PIR movement sensor. The Ablaze Premium Back-Lit Mirrors come in two parts: the mirror with hangers and demister attached and the backbox containing the lights and transformer. There is a small screw used to secure these two parts together during transportation which needs to be removed prior to installation.

Installation

1. Switch off the main power

You will be installing the Ablaze Back-Lit Mirror as part of a high voltage mains electrical circuit. To ensure your safety and to protect the mirror, switch off the mains power before you start the installation.

2. Plan the installation and layout

The Ablaze Back-Lit Mirrors require mains supply and a switch/timer/PIR movement sensor. Measure out and install all the necessary items before you install the mirror.

3. Fix the backbox to the wall and connect to main supply

Remove the small fixing screw that holds the backbox to the mirror (see diagram below) and lift the backbox away from the mirror. Place the backbox onto the wall central to your desired final position. Whilst in position mark the four fixing holes. Drill pilot holes in the four marked position and insert wall plugs. Screw the backbox into position. Pull the mains supply cable through the centre of the backbox and wire into the connection block.

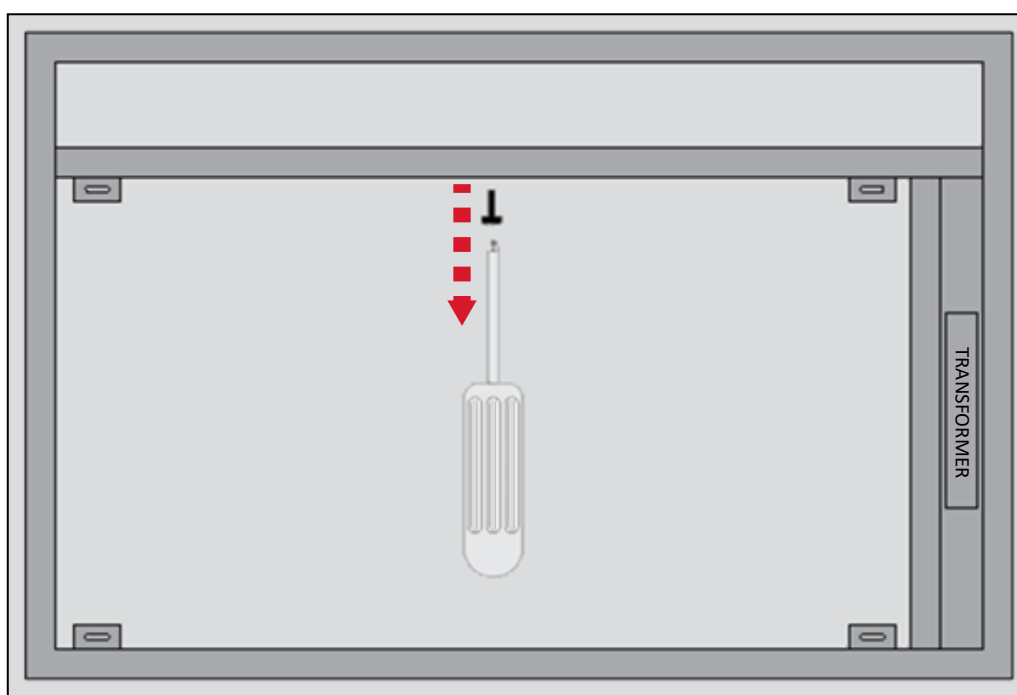

Please note the location of the screw will differ for each model

4. Hang the mirror onto the backbox

Connect the Thermomirror demister by slotting the black cable from the back of the mirror into the black cable at the connection block. Line up the mirror above the backbox and gently lower the mirror until the brackets clip into place and you can feel the backbox take the weight of the mirror.

Technical Specifications

CODE	LIGHT	SIZE (MM)	MOUNTING	OUTPUT WATTAGE	DEMISTER INCLUDED
S500C	Cool	W750 x H500 x D45	L / P	35	Y
S759C	Cool	W900 x H750 x D45	L / P	57	Y
S900C	Cool	W900 x H900 x D45	N/A	83	Y
S1200C	Cool	W1200 x H800 x D45	L / P	92	Y
S1500C	Cool	W1500 x H800 x D45	L / P	111	Y
SR759C	Cool	W900 x H750 x D45	L / P	62	Y
SR1118C	Cool	W1200 x H800 x D45	L / P	86	Y
RB610W	Warm	610 ø x D45	N / A	18	N
RB610C	Cool	610 ø x D45	N / A	18	N
SS759C	Cool	W900 x H750 x D45	L / P	85	Y
SS128C	Cool	W1200 x H800 x D45	L / P	108	Y
RS600C	Cool	600 ø x D45	N / A	37	Y
RS600W	Warm	600 ø x D45	N / A	37	Y
RS900C	Cool	900 ø x D45	N / A	80	Y
RS900W	Warm	900 ø x D45	N / A	80	Y
SO500C	Cool	W500 x H1000 x D45	P	61	Y
SO500W	Warm	W500 x H1000 x D45	P	61	Y
SSC128C	Cool	W1200 x H800 x D45	L	108	Y
AS500C	Cool	W500 x H800 x D45	P	47	Y
AS500W	Warm	W500 x H800 x D45	P	47	Y

P = Portrait Mounting

L = Landscape Mounting

Supply Voltage	240V 50Hz
Wiring Method	Hardwired
Warranty	3 Years
Ligthning Type	LED

Safety Information

Ablaze Back-lit Mirrors should be installed and tested by a qualified electrician and in accordance with current local regulations. Where possible, the Ablaze Back-Lit Mirror should be screwed into studs or other suitable dry wall anchors, if fixing to hollow walls, suitable anchors should be used.

Please read and understand this installation guide before commencing installation.

If you have any queries in regards to installation, please call 1300 368 631.

- Observe and adhere to electrical guidelines when placing your Ablaze Back-Lit Mirror in wet areas.
- Ensure any timers or switches used are installed in correct zones according to the IP rating of the timer/switch.

Care Information

For best results, clean mirrors with methylated spirits and water at a rate of 30% methylated spirits and 70% water. Do not use Windex or similar chemical cleaning products. Avoid getting water on the sides or back of the mirror as damage to the silver backing can occur. In coastal areas it is recommended to wipe around the edge of the mirror once a month to avoid salt build up that can cause silver creep.

Warranty Registration

Thermogroup covers all its products with a satisfaction guarantee. In addition, Thermogroup will supply a replacement product where a fault is shown to be caused by manufacture, materials or workmanship providing the goods have been installed correctly and according to installation instructions. This guarantee does not include removal, freight or installation costs.

To use the warranty, repair or service, the customer must provide purchase invoice/receipt.

If the product develops a fault within the warranty period due to normal wear and tear, Thermogroup at its discretion will recognise whether it's a faulty product or not. If it is impossible or not economical for the manufacturer to repair the product, the manufacturer will replace the faulty product with a new unit of the same model or if there is no stock available of the same model as the product, the manufacturer will replace the product with a new unit of a similar size. No responsibility can be taken for altered dimensions and lining up of existing holes.

The repair service offered within the warranty period only covers the faults and problems as developed from the manufacturer's errors. Any damage caused by improper use, carelessness or incorrect wiring is not covered.

Thermogroup is not responsible for any monetary loss or injuries caused by improper use of this product.

Our goods and services come with guarantees that cannot be excluded under the Australian Consumer Law. For major failures with the service, you are entitled: to cancel your service contract with us; and to a refund for the unused portion, or to compensation for its reduced value.

You are also entitled to choose a refund or replacement for major failures with goods. If a failure with the goods or a service does not amount to a major failure, you are entitled to have the failure rectified in a reasonable time. If this is not done, you are entitled to a refund for the goods and to cancel the contract for the service and obtain a refund for the unused portion. You are also entitled to be compensated for any other reasonably foreseeable loss or damage from a failure in the goods or service.



Contact Us

Phone: 1300 368 631 | Technical Helpline: 1300 989 464
sales@thermogroup.com.au | www.thermogroup.com.au