

Thermorail Towel Rail

Vertical Non-Heated Towel Rail

Installation Guide

Please read these instructions carefully and in full before installation.



Check you've got everything

- Thermorail Single Vertical Bar Rail
- Screw Kit including:
 - 2 x Mounting Brackets
 - 2 x Wall Plugs
 - 2 x Countersunk Screws
 - 4 x M5x5 Grub Screws (2 spares)
 - 2 x M5x3 Grub Screws (1 spare)
 - 1 x Hook
 - 1 x Allen Key

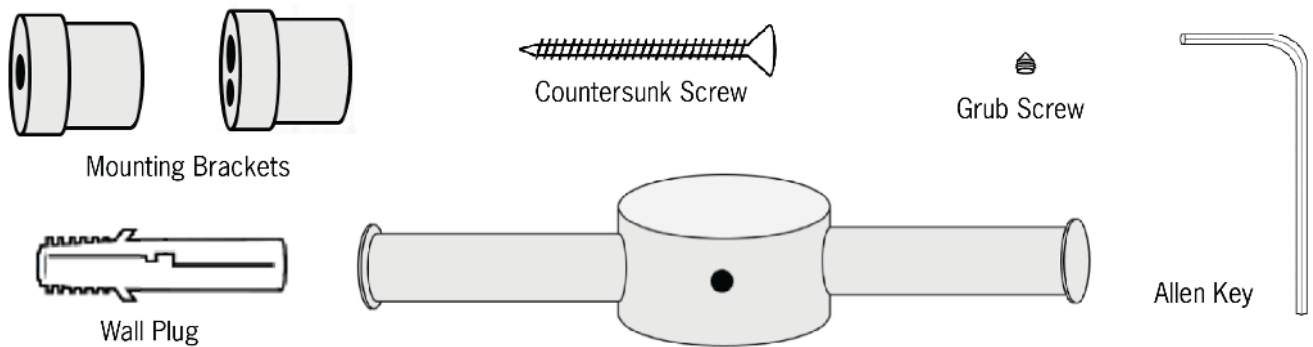

Please note these are not to scale

You will also need:

- Cross Head Screwdriver
- Pencil
- Spirit Level
- Tape Measure
- Drill Bits
- Cordless Drill

Safety Information

We recommend that the rail is installed onto a flat uniform wall and where possible the Towel Rail should be screwed into studs or if fixing to hollow walls suitable anchors should be used to ensure rail is secure.

- Do not use the towel rail to hold towels or other articles that have been in contact with oil, petroleum based products or dry cleaning fluids
- Do not immerse your rail in any liquid

WARNING: In order to avoid a hazard for very young children, this appliance should be installed so that the base of the rail is at least 600mm above the floor.

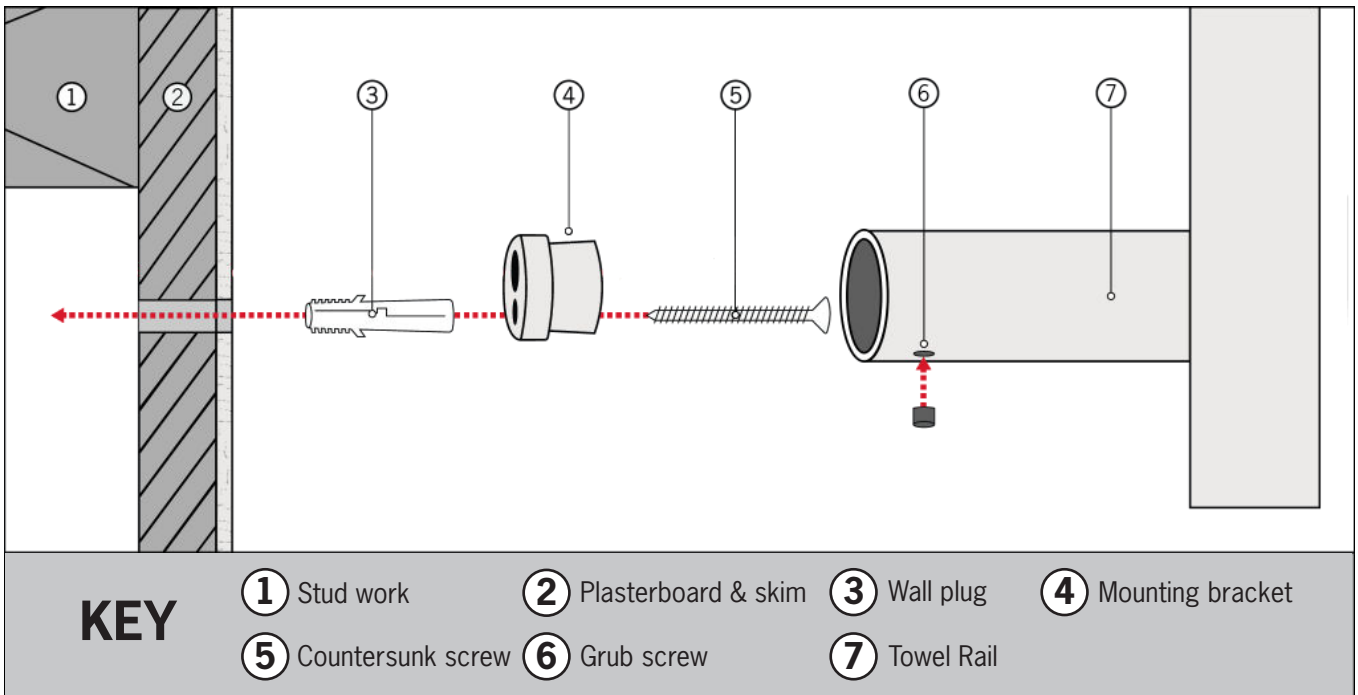

1. Install two wall brackets

Measure and mark out the bracket positions making sure they are level. Drill a 8mm hole for each of the two wall brackets and insert suitable wall plugs. Fix the two mounting brackets in place using a screwdriver and screws.

2. Fix Thermorail to the wall

Fit the Thermorail to the mounting brackets installed on the wall. You may need assistance to hold the rail in place. Tighten the grub screws on the two wall mount arms using the allen key provided.

3. Fix the hook to the vertical bar

Please note that the hook is optional. Slide the hook over the top of the vertical bar (ensuring that the grub screw hole is facing towards the wall) and hold in desired position. Use the short grub screw to fix in position.

Technical Specifications

CODE	NO. OF BARS	FINISH	SIZE (MM)	WARRANTY
UVS900H	1	Polished	W142xH900xD100	10
UVS900HBR	1	Brushed	W142xH900xD100	7
UVS900HB	1	Matt Black	W142xH900xD100	7

Care Information

The finish of your Thermorail Non-Heated Towel Rail is hard wearing and easy to maintain. However, any harsh scrubbing, scratching or acid based cleaning products will damage the surface of your towel rail. Cleaning with a soft cloth and a non-abrasive cleaning agent will give the best results.

Warranty Information

Thermogroup covers all its products with a satisfaction guarantee. In addition, Thermogroup will supply a replacement product where a fault is shown to be caused by manufacture, materials or workmanship providing the goods have been installed correctly and according to installation instructions. This guarantee does not include removal, freight or installation costs. Our goods come with guarantees that cannot be excluded under Australian Consumer Law. You are entitled to a replacement or refund for a major failure and compensation for any other reasonably foreseeable loss or damage. You are also entitled to have the goods repaired or replaced if the goods fail to be of acceptable quality and the failure does not amount to a major failure.

The details on the length of the warranty on the Non-Heated Vertical Bars is on page 3 of this installation guide. To use the warranty, repair or service the customer must provide purchase invoice/receipt and have completed the online warranty registration form. If the product develops a fault within the warranty period due to normal wear and tear, Thermogroup at its discretion will recognise whether it's a faulty product or not. If it is impossible or not economical for the manufacturer to repair the product, the manufacturer will replace the faulty product with a new unit of the same model or if there is no stock available of the same model as the product, the manufacturer will replace the product with a new unit of a similar size. No responsibility can be taken for altered dimensions and lining up of existing holes.

The repair service offered within the warranty period only covers the faults and problems as developed from the manufacturer's errors. Any damage caused by improper use or carelessness or incorrect wiring is not covered. Thermogroup is not responsible for any monetary loss or injuries caused by improper use of this product.

Warranty Registration

The Thermorail Heated Towel Rail warranty against manufacturers defects is a limited liability warranty and will only apply if the product is registered online. Online registration must be completed within 60 days of installation. Failure to complete the warranty registration will void the warranty.

Thermogroup



Contact Us

Phone: 1300 368 631 | Technical Helpline: 1300 989 464
sales@thermogroup.com.au | www.thermogroup.com.au