

# Mid Wave Outdoor Heaters

## **Ash Range**

A01200RB, A02000RB & A02500RB

## **Cedar Range**

C01200RB & C01800RB

## Installation Guide

Please read these instructions carefully and in full before installation.  
Hardwire Installation should be carried out by a qualified electrician.

# Contents

Installation Do's & Don'ts .....	3
Product Features.....	4
Assembly of Cedar Heaters.....	6
Installation for Ash Heater.....	6
Position Guidelines and Distances.....	8
Operating Instructions.....	9
Maintenance and Cleaning.....	10
Warranty Information.....	11
Contact Us .....	12

# Installation Do's & Don'ts



The Heaters are 240Volt and all hardwired electrical installations must be carried out by a licensed electrician to current local regulations.



The element is operating at around 800-1200°C so the heater will be extremely hot when in use and for a period after it has been switched off. To avoid burns, do not let bare skin touch the unit. Keep combustible materials, such as furniture, pillows, bedding, papers, clothes and curtains at least 150cm from the front of the heater and keep them away from the sides and rear.



Extreme caution is necessary when any heater is used by or near children or invalids and whenever the heater is left operating and unattended.



A heater has hot and arcing or sparking parts inside. Do not use it in areas where flammable liquids/vapours are used or stored.



This product contains two AAA batteries. If a new or used AAA battery is swallowed it can cause severe internal burns and can lead to death in as little as 2 hours. Always completely secure the battery compartment. If the battery compartment does not close securely, stop using the product, remove the batteries, and keep them away from children. If you think batteries might have been swallowed seek immediate medical attention.

## Do's

- ✔ Ensure that you read all provided instructions before installing or operating this heater.
- ✔ Disconnect heater, turn controls to off, and turn off power to heater circuit at main disconnect panel before touching, cleaning or moving the heater.
- ✔ Use this heater only as described in this manual. Any other use not recommended by Thermogroup may cause fire, electric shock or injury to persons.
- ✔ Follow correct installation as any alterations to the heater, as well as failure to adhere to the warnings and instructions contained within this manual, may cause property damage, personal injury or death.
- ✔ Ensure that all packaging material is kept out of reach of children.
- ✔ After unpacking, make sure the heater shows no signs of visible damage or tampering. If the appliance appears damaged, contact the place of purchase for assistance.
- ✔ Keep the cable away from sharp edges during handling and installation.
- ✔ Plug the heater into a suitably rated powerpoint that is earthed.

## Don'ts

- ✘ Do not use any heater after it malfunctions. Disconnect power at powerpoint or isolation switch and have the heater inspected by a reputable electrician before reusing.
- ✘ Do not insert or allow fingers or other objects to enter the heater, as this may result in an electrical shot or burns.
- ✘ Do not block air intakes or cover the heater as doing so may result in a electrical fire.
- ✘ Never attempt to alter the product in any way.
- ✘ This appliance is not intended for use by persons (including children) with reduced physical, sensory or mental capabilities, or lack of experience and knowledge, unless they have been given supervision or instruction concerning use of the appliance by a person responsible for their safety.
- ✘ Do not touch any part of the heater or plug with wet or moist hands.
- ✘ Do not run the power cord under the carpet or cover with throw rugs, runners etc. over the cord and arrange so people will not trip over it.
- ✘ Do not allow the supply cord to sit or hang in front of the heater while in use and keep it away from the body of the heater which will get hot during operation.

**If you are unsure or need any help, please call our team on 1300 989 464**

# Product Features — Ash Wall/Ceiling Mounted Heater

The carbon infrared heater is engineered as a robust outdoor heater. Every component in the heater is optimised for performance. That includes the carbon infrared tube producing mid wave infrared heat. The heater has a weatherproof design, which means you can use it for patios, terraces, smoking areas, conservatories, restaurants, hotels, garages, workshops, factories, warehouses and much more.

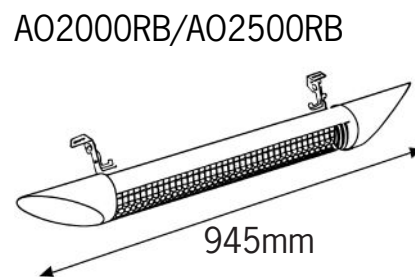
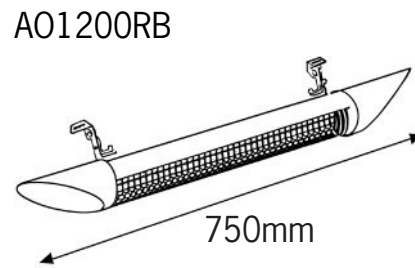
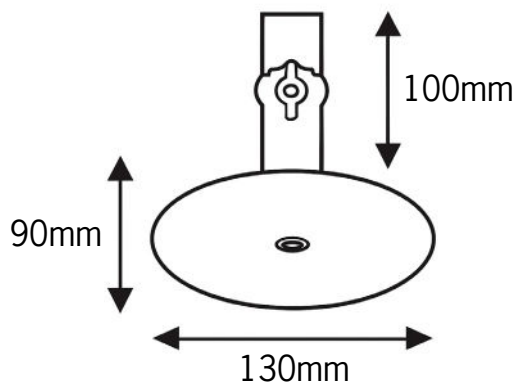

	Ash AO1200RB	Ash AO2000RB	Ash AO2500RB
Width	130mm	130mm	130mm
Length	750mm	945mm	945mm
Distance from wall	190mm	190mm	190mm
Voltage	240V AC	240V AC	240V AC
Frequency	50/60Hz	50/60Hz	50/60Hz
Power	1200Watts	2000Watts	2500Watts
Power Settings	400/800/1200W	700/1400/2000W	800/1600/2500W
Wiring Type	Lead and plug	Lead and plug	Lead for hardwiring
Lead Length	1.7m	1.7m	1.7m
Area	Up to 10m <sup>2</sup>	Up to 20m <sup>2</sup>	Up to 25m <sup>2</sup>
IP Rating	IP55	IP55	IP55
Warranty	2 years	2 years	2 years

# Product Features — Cedar Freestanding Heater

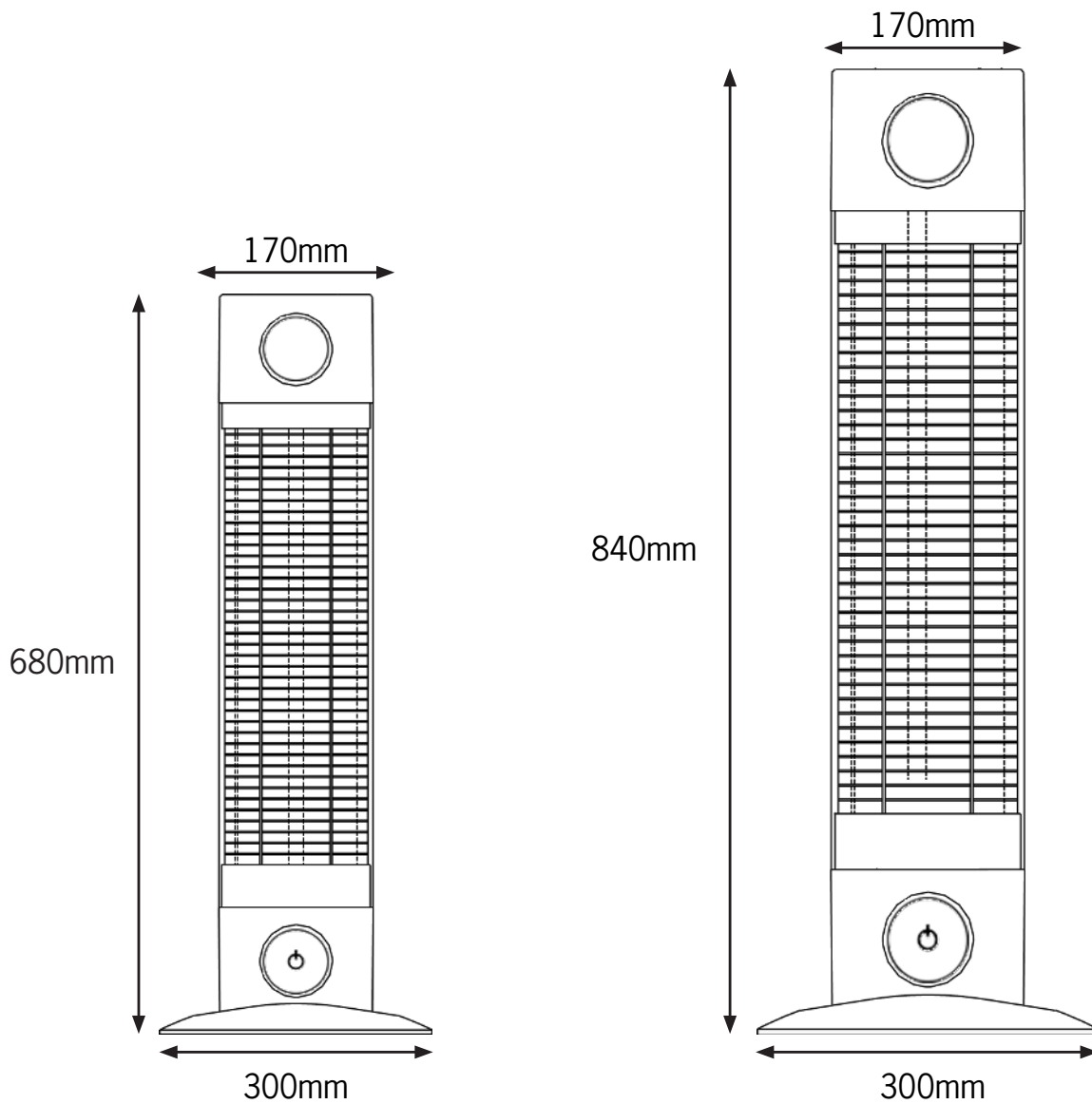

	<b>Cedar CO1200RB</b>	<b>Cedar CO1800RB</b>
Height	680mm	840mm
Width	300mm	300mm
Depth	300mm	300mm
Voltage	240V AC	240V AC
Frequency	50/60Hz	50/60Hz
Power	1200Watts	1800Watts
Power Settings	400/800/1200W	600/1200/1800W
Area	Up to 15m <sup>2</sup>	Up to 20m <sup>2</sup>
Warranty	2 years	2 years

## Safety Information

- Never attempt to carry out an assembly or installation while the electrical power is switched on.
- Remove all protective plastic from the heater before assembly or installation.
- Ensure that you refer to the installation precautions under the installation Do's and Don'ts on page 3 before starting to assemble or install the heater.
- Do not place articles on or against this heater.
- Only connect the appliance to a power supply that conforms to the specifications stated on the heater on page 3 before starting to assemble or install the heater.

## Assembly of Cedar Heaters

- Remove the heater and base from the packaging and inspect for damage.
- Secure the base to the heater with the 4 screws provided.

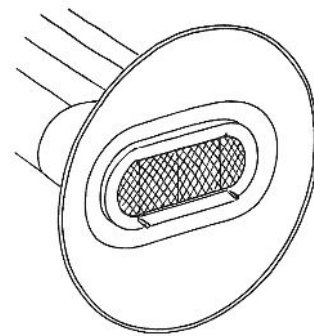
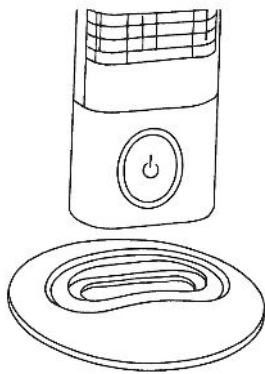

# Installation for Ash Heaters

- For installation use only the supplied brackets or suitable fixings to mount the brackets to your surface.
- This heater must be installed according to the minimum installation clearances shown in the diagrams on page 8.

Once you have selected your position (refer to the diagram on page 8) install the heater as per the below.

1. Insert the two brackets (A) into the heater and secure tightly with M6 wing nuts (C)
2. Mark and drill the mounting holes on the wall. Using the screws (D) and wall plugs (E) provided or fixings suitable to your wall/ceiling type, attach the 2 mounting brackets (A) to the wall/ceiling.
3. Bring the heater up to the mounting bracket. Insert M6 bolts (B) in the slots on the bracket. Lock into position with M6 wing nuts (C).
4. Rotate the heater to required angle and lock into position with the bolt and nut onto the wall bracket.

**If the heater is being installed vertically or at an angle the supply cable must be at the lower end of the heater.**

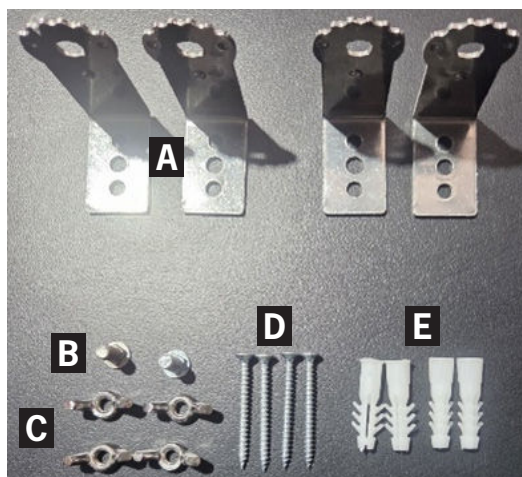

- A: 4 x Mounting bracket
- B: 2 x Bolts for brackets
- C: 4 x Wing nuts for brackets
- D: 4 x Mounting screws
- E: 4 x Wall plugs (4)

## Correct Installation of Brackets

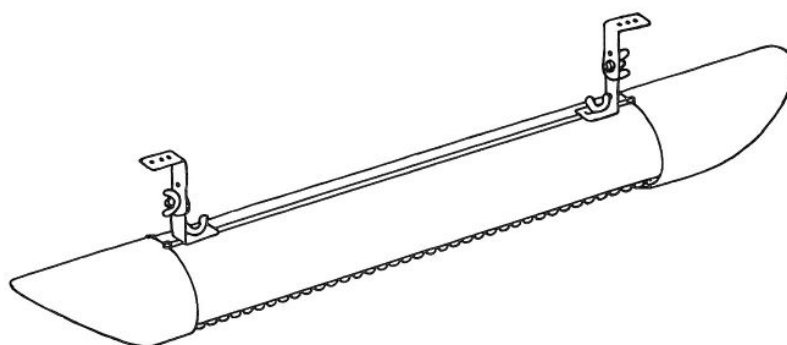
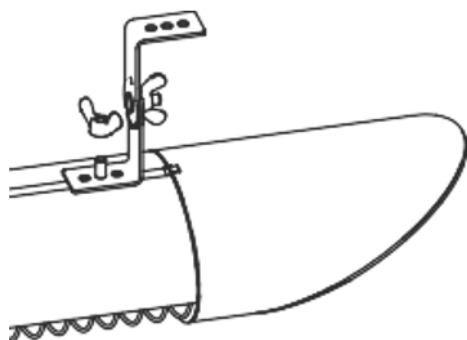

# Position Guidelines and Distances

- A minimum safety distance of 1500mm should always be left in front of the appliance.
- This heater must be mounted at a minimum of 1800mm above the floor.
- The heater should always have a minimum clearance of 500mm from a ceiling and adjacent walls.

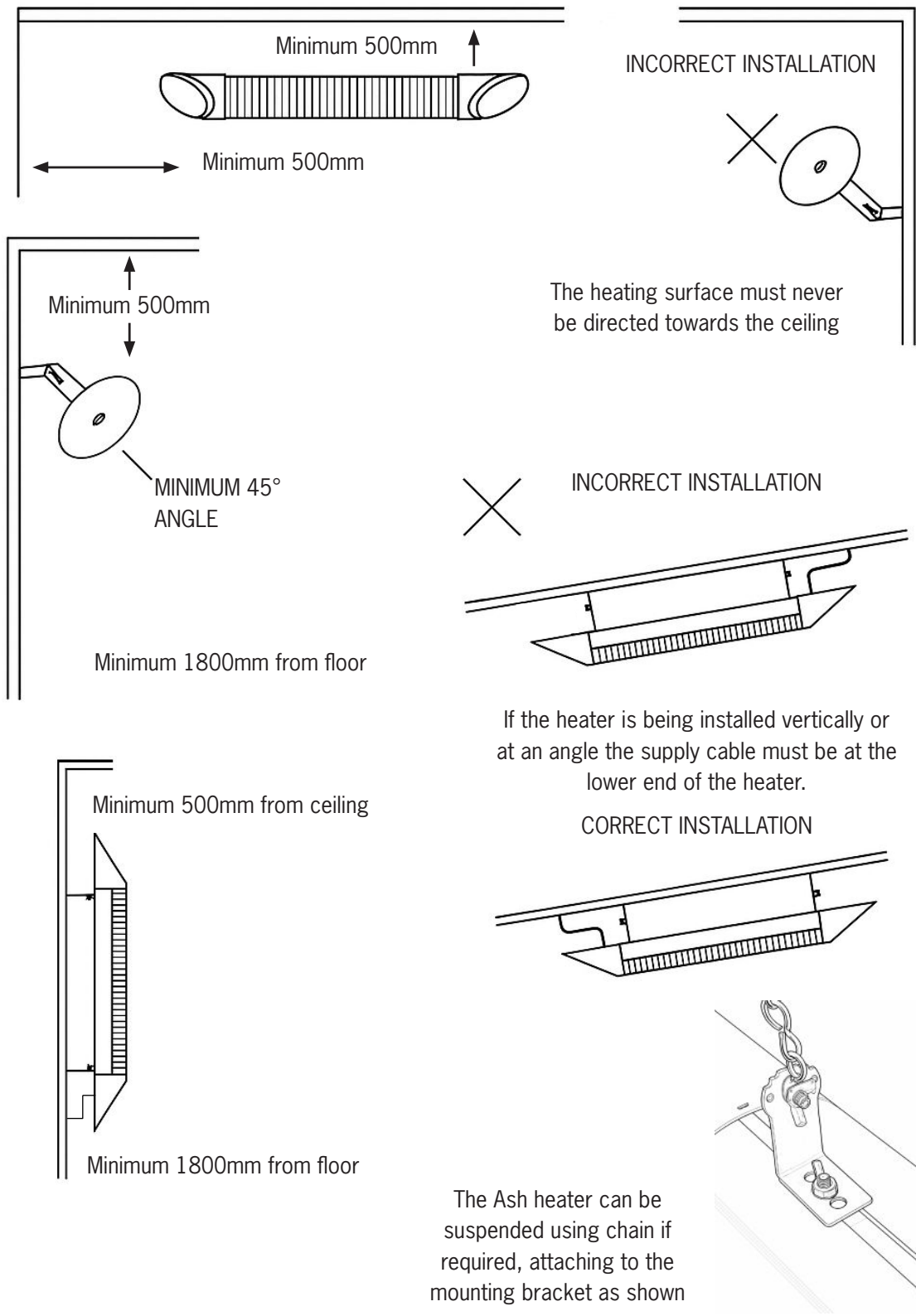

# Operating Instructions

The heaters come with a remote, this allows you to select High, Medium or Low, run the heater via the built in thermostat or select a countdown timer from 1–9 hours. You can also control the heater via the unit directly (only 3 power settings).

- ⬆️ Press the up button to turn the heater on at high or to increase level or change the heat setting, P3 will show on unit, indicating the heater is on high.
- ⬇️ Press the down button to turn the heater on at the low level or change the heat setting, P1 will show on the unit, indicating the heater is on low.
- + Press the plus and minus buttons to set the required temperature. The heater will adjust when the temperature has been reached (set temperature shows on screen).
- 
- 🕒 Press the button repeatedly to select the number of hours you want the heater to operate.

Number of hours will show on the screen.

Once the selected period has been completed the heater will turn off.

During the selected period, press the clock once to see remaining time.

- 🕒 Press the button to switch the unit off.



You can also operate the heater via the button on the heater – but you can only select high (P3), medium (P2), or low (P1).

## Installing or Replacing Remote Control Batteries

Replace both batteries when the remote control stops operating or its range seems reduced. To do this slide the battery compartment cover off. Make sure you observe the - and + symbols on the batteries when inserting 2 new AAA batteries and replace the cover. Dispose of old batteries according to regulations in your state. (Batteries not included, 2x AAA required)

# Maintenance and Cleaning

Always disconnect the heater from the electricity supply and allow adequate time (minimum of 30 minutes) for it to cool completely before adjusting the position or attempting to work on it.

If the heater has collected dust or dirt inside the unit or around the heating element, carefully remove the dust/dirt being careful not to damage the heating element. Do not operate the heater in this condition.

Usually the only maintenance required is cleaning of the external surfaces of the heater.

Do not use powerful abrasive or solvent cleaning fluids when cleaning the heater. Use a damp cloth to wipe the outside of the heater.

If removed from its mounting position when not in use, store the heater carefully in a safe, dry, childproof location.

Do not touch the heating element with bare fingers, as residue from your hand could affect the life of the lamp. If it is accidentally touched, remove the finger marks with a soft cloth moistened with methylated spirit or rubbing alcohol. Ensure it is totally dry before turning on.

Do not attempt to repair or adjust any electrical or mechanical functions on this heater.

The heater contains no user serviceable parts. Check for damage to the appliance regularly. If damage to the appliance is suspected, discontinue use immediately and contact the supplier or qualified person to repair it.

# Warranty

Thermogroup covers all its products with a satisfaction guarantee. In addition, Thermogroup will supply a replacement product where a fault is shown to be caused by manufacture, materials or workmanship providing the goods have been installed correctly and according to installation instructions. This guarantee does not include removal, freight or installation costs. Our goods come with guarantees that cannot be excluded under Australian Consumer Law. You are entitled to a replacement or refund for a major failure and compensation for any other reasonably foreseeable loss or damage. You are also entitled to have the goods repaired or replaced if the goods fail to be of acceptable quality and the failure does not amount to a major failure.

The Ash and Cedar Outdoor Heaters have a 2 Year warranty. To use the warranty, repair or service the customer must provide purchase invoice, receipt, and any other relevant details.

If the product develops a fault within the warranty period due to normal wear and tear, Thermogroup at its discretion will recognise whether it's a faulty product or not. If it is impossible or not economical for the manufacturer to repair the product, the manufacturer will replace the faulty product with a new unit of the same model or if there is no stock available of the same model as the product, the manufacturer will replace the product with a new unit of a similar size. No responsibility can be taken for altered dimensions and lining up of existing holes.

The repair service offered within the warranty period only covers the faults and problem as developed from the manufacturer's errors. Any damage caused by improper use or carelessness or incorrect wiring is not covered.

Thermogroup is not responsible for any monetary loss or injuries caused by improper use of this product.



## Contact Us

Phone: 1300 368 631 | Technical Helpline: 1300 989 464  
sales@thermogroup.com.au | www.thermogroup.com.au